

WALL MOUNTED DRINKING FOUNTAIN

DWF01

Special Features

- ▲ HYGIENIC AND VANDAL RESISTANT
- ▲ SMOOTH RADIUSED DESIGN
- ▲ INTEGRAL SPLASHBACK
- ▲ EASILY INSTALLED AT ADULT OR JUNIOR HEIGHT
- ▲ UNDERSHROUD TO CONCEAL PIPEWORK

DWF01 - WITHOUT SHROUD



Description

The wall mounted drinking fountain is hygienic, robust and easily installed at adult or junior height. The shielded bubbler valve is positioned for ease of use and the smooth radiused design eliminates sharp corners which can cause injury. The drinking fountain is available with either integral wall mounting brackets or a half height undershroud, with removable access panel, to conceal the supply and waste pipework.

Construction

The drinking fountain is manufactured in one piece without joints or crevices from grade 304 stainless steel, with all exposed surfaces polished to a satin finish.

For ease of cleaning and hygiene a splashback is incorporated in the top of the drinking fountain. The integral half height undershroud incorporates a removable access panel held in position by security type screws.

Each drinking fountain is supplied with a flush grated waste fitting and a chrome plated shielded bubbler complete with a self closing push button valve.



DWF02 - WITH SHROUD

Technical Specification: Wall Mounted Drinking Fountain

DWF01 - WITHOUT SHROUD

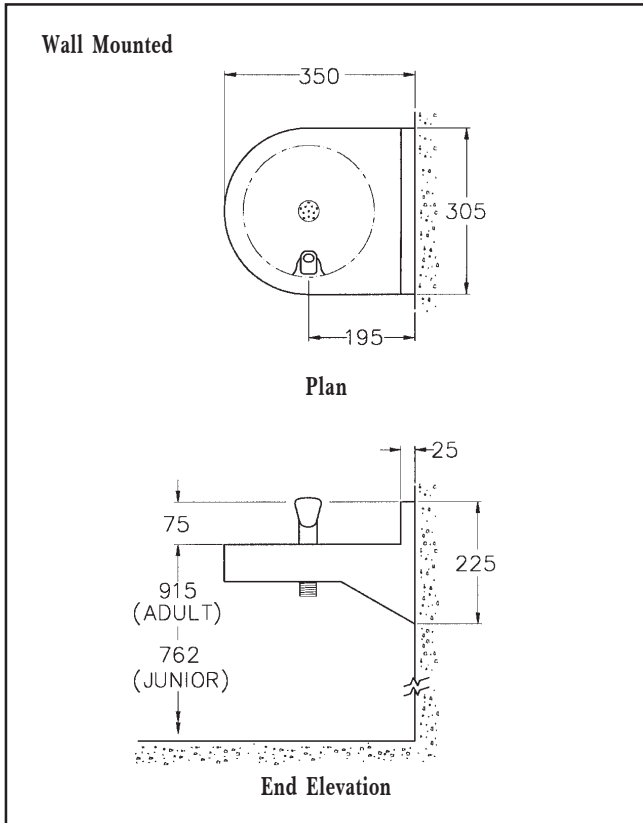

Waste Outlet

The drinking fountain is supplied with a 32 mm (1¼ in) BSP flush grated waste fitting.

Bubbler Valve

The drinking fountain is supplied with a chrome plated shielded bubbler with self closing push button valve. The valve incorporates a flow adjuster and strainer and is supplied with a water inlet fitting to suit 15 mm diameter pipework.

Product Code Selection for Order or Quotation

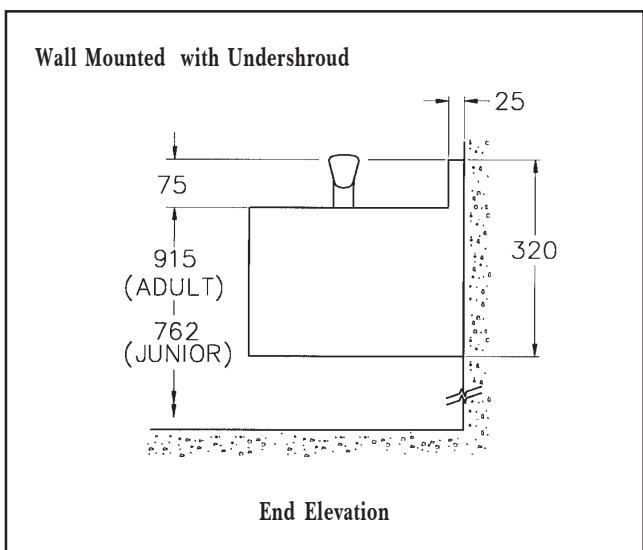

DWF02 - WITH SHROUD